

Scotch Yoke Pneumatic Actuator



● Scotch Yoke Pneumatic Actuator

The **BM Series** pneumatic actuator is designed using Scotch-Yoke technology. Scotch-Yoke technology is well known to all users as the most suitable actuator mechanism for valve and damper operation as it produces higher torque at both end position. The latest manufacturing technologies have been operated in order to supply a high quality and cycle-life on **actuator**. Our extensive inventory & engineering capabilities allow us to provide reliable and safety product to our customer with satisfaction.

● SPECIFICATION

Pressure Range	Maximum Working Pressure : 10 Bar(143 Psi)
Temperature Range	Standard: -20°C~80°C Low: -40°C~110°C High: -20°C~150°C
Movement	90 degree +5~ -10 (optional -30 degree)
Lubrication	All moving parts are lubricated for long life cycle.
Life Cycle	More than 1,000,000 Operations.

Specification is subject to change without prior notice

FEATURES

Center Stopper Bolt

Adjustment for open & close positions
 90 degree : adjustable +5 ~ -10 degree
 Max : -30 degree



Mounting Holes

Easy to mount accessory
 VDI/VDE 3845 NAMUR

NAMUR Drive Shaft

Mechanical Stopper

Cylinder

Hard anodized aluminum

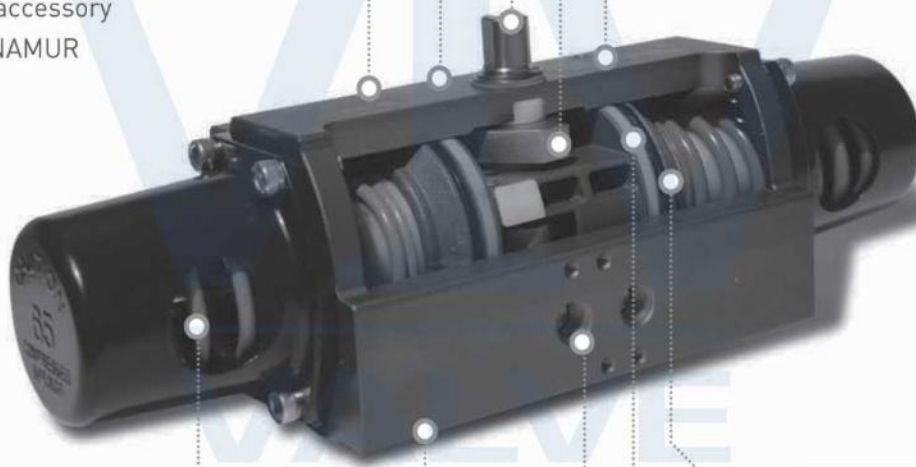

Spring Pack

Pre-compressed for safety

O-Ring

Specially treated for reducing friction

Mounting Holes

International standard
 ISO5211, DIN3337, NAMUR

Guide Ring

For longer working life cycle

Direct Mounting NAMUR

Double Square Drive Shaft

ISO5211 NAMUR

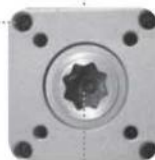

Specification is subject to change without prior notice

PART LIST (BM - SERIES)

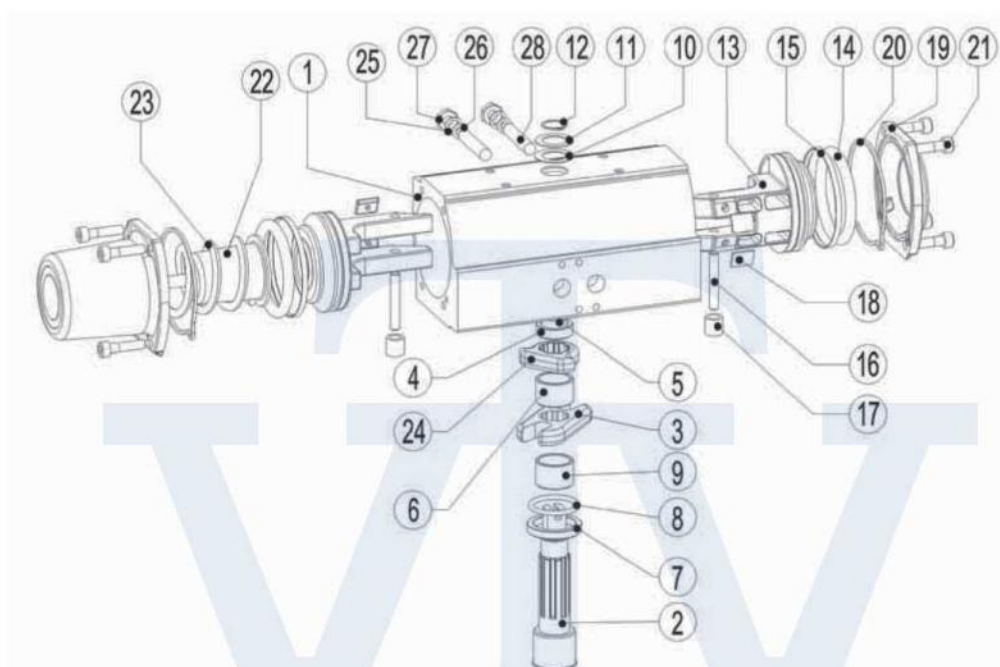

NO.	Part Name	Materials	NO.	Part Name	Materials
1	Body	Aluminum Alloy	15	Piston Guide-ring	Engineering Plastic
2	Shaft	Steel Alloy (Nickel Plated)	16	Piston Pin	Steel Alloy
3	Crank	Steel Alloy	17	Piston Roller	Steel Alloy
4	Bushing (Top)	Engineering Plastic	18	Piston Pad	Engineering Plastic
5	Body O-ring (Top)	NBR	19	Cover	Aluminum Alloy
6	Shaft Roller (Top)	Engineering Plastic	20	Cover O-ring	NBR
7	Bushing (Bottom)	Engineering Plastic	21	Cover Bolt	Steel Alloy
8	Body O-ring (Bottom)	NBR	22	Spring Cap	Engineering Plastic
9	Shaft Roller (Bottom)	Engineering Plastic	23	Spring	Steel Alloy
10	Body Washer (Bottom)	Engineering Plastic	24	Stopper	Steel Alloy
11	Body Washer (Top)	Stainless Steel	25	Adjust Washer	Stainless Steel
12	Body Snap-ring	Stainless Steel	26	Adjust Nut	Stainless Steel
13	Piston	Aluminum Alloy	27	Adjust O-ring	NBR
14	Piston O-ring	NBR	28	Adjust Bolt	Steel Alloy

Specification is subject to change without prior notice

DIMENSION

DOUBLE ACTING

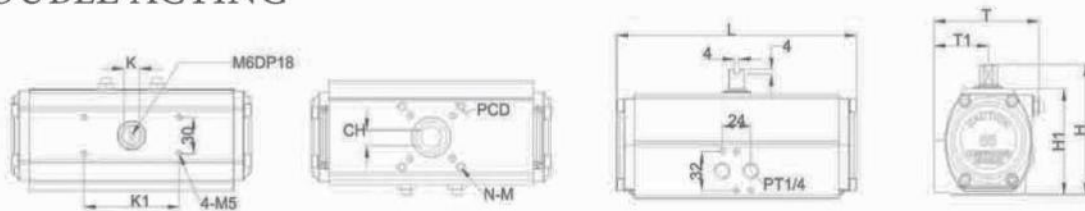

MODEL	K1	ISO5211	P.C.D(∅)	N-M	K	L	T	T1	H	H1	CH	DTH	WG(Kg)
BM 50 DA	80	F03/F05/F07	36/50/70	4-M5/M6/M8	10	162	75	40	90	70	11x11 14x14	13 14	1.6
BM 65 DA	80	F05/F07	50/70	4-M6/M8	13	198	89	46	107	87	14x14	17	2.7
BM 80 DA	80	F07	70	4-M8	17	262	101	49.5	126	106	17x17	19	4.3
BM 100 DA	80	F07/F10	70/102	4-M8/M10	22	311	129	61.5	148	128	22x22	26	7.5
BM 125 DA	80	F07/F10	70/102	4-M8/M10	22	390	151	72	174	154	22x22	26	11.6
BM 140 DA	80	F10/F12	102/125	4-M10/M12	22	445	162	77	190	170	27x27	30	18
BM 160 DA	80	F14	140	4-M16	32	529	181	88	210	190	36-36	42	26
BM 210 DA	130	F16	165	4-M20	36	605	231	115	284	254	46x46	60	47.2

UNIT : mm

SPRING RETURN

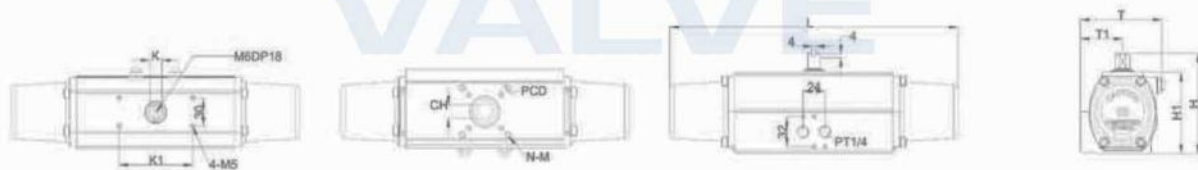

MODEL	K1	ISO5211	P.C.D(∅)	N-M	K	L	T	T1	H	H1	CH	DTH	WG(Kg)
BM 50 SR	80	F03/F05/F07	36/50/70	4-M5/M6/M8	10	257	75	40	90	70	11x11 14x14	13 14	1.7
BM 65 SR	80	F05/F07	50/70	4-M6/M8	13	314	89	46	107	87	14x14	17	3.4
BM 80 SR	80	F07	70	4-M8	17	430	101	49.5	126	106	17x17	19	5.7
BM 100 SR	80	F07/F10	70/102	4-M8/M10	22	500	129	61.5	148	128	22x22	26	10.6
BM 125 SR	80	F07/F10	70/102	4-M8/M10	22	606	151	72	174	154	22x22	26	17.9
BM 140 SR	80	F10/F12	102/125	4-M10/M12	22	710	162	77	190	170	27x27	30	24.5
BM 160 SR	80	F14	140	4-M16	32	815	181	88	210	190	36-36	42	36
BM 210 SR	130	F16	165	4-M20	36	982	231	115	284	254	46x46	60	76.9

Specification is subject to change without prior notice

TORQUE



DOUBLE ACTING OUTPUT TORQUE

Committed to continuous improvement

Model	Angle	Supply Air:3Bar		Supply Air:4Bar		Supply Air:4.5Bar		Supply Air:5Bar		Supply Air:6Bar	
		Air to Close	Air to Open	Air to Close	Air to Open	Air to Close	Air to Open	Air to Close	Air to Open	Air to Close	Air to Open
50 DA	0°	29.0	21.0	37.0	28.0	37.5	32.5	38.0	37.0	42.0	41.0
	45°	15.0	16.0	20.0	21.0	22.5	23.5	25.0	26.0	30.0	31.0
	90°	25.0	25.0	33.0	38.0	36.0	39.0	39.0	40.0	50.0	52.0
65 DA	0°	63.0	59.0	85.0	78.0	95.0	86.5	105.0	95.0	131.0	116.0
	45°	33.0	38.0	45.0	49.0	51.0	56.0	57.0	63.0	68.0	73.0
	90°	54.0	52.0	72.0	71.0	80.0	82.0	88.0	93.0	107.0	107.0
80 DA	0°	121.0	105.0	164.0	143.0	160.0	163.0	156.0	183.0	261.0	210.0
	45°	65.0	69.0	84.0	92.0	98.0	106.5	112.0	121.0	130.0	144.0
	90°	97.0	101.0	130.0	133.0	150.5	144.5	171.0	156.0	198.0	209.0
100 DA	0°	194.0	186.0	265.0	247.0	298.5	269.5	332.0	292.0	393.0	368.0
	45°	110.0	127.0	147.0	165.0	166.0	180.5	185.0	196.0	237.0	250.0
	90°	173.0	179.0	231.0	237.0	264.0	269.0	297.0	301.0	348.0	363.0
125 DA	0°	428.0	432.0	576.0	551.0	650.5	614.5	725.0	678.0	886.9	793.9
	45°	255.0	273.0	339.0	360.0	382.0	401.5	425.0	443.0	513.0	531.0
	90°	385.0	375.0	510.0	491.0	572.5	552.0	635.0	613.0	750.0	732.0
140 DA	0°	623.0	576.0	829.9	753.9	967.4	838.4	1104.9	922.9	1310.9	1096.9
	45°	333.0	331.0	450.0	455.0	514.5	518.5	579.0	582.0	691.0	668.0
	90°	520.0	523.0	689.0	720.0	775.9	799.9	862.9	879.9	1054.9	969.9
160 DA	0°	952.9	812.9	1146.9	1061.9	1315.9	1186.9	1484.9	1311.9	1799.9	1599.9
	45°	540.0	569.0	730.0	757.9	824.9	853.4	919.9	948.9	1109.9	1132.9
	90°	879.9	978.9	1169.9	1319.9	1308.9	1477.4	1447.9	1634.9	1749.9	2026.9
210 DA	0°	1979.9	1909.9	2799.8	2599.8	2939.8	2859.8	3299.8	3199.8	3919.7	3819.7
	45°	1099.9	1149.9	1459.9	1499.9	1709.9	1749.9	1919.9	1949.9	2299.8	2399.8
	90°	1669.9	1719.9	2149.9	2299.8	2599.8	2709.8	2799.8	2899.8	3349.8	3449.8

Unit : N-m



● SPRING RETURN OUTPUT TORQUE

Maximize the torque

Model	Angle	Spring torque: Weak			Spring torque: Middle				Spring torque: Strong			
		Spring	Air:3Bar	Air:4Bar	Spring	Air:4Bar	Air:4.5Bar	Air:5Bar	Spring	Air:6Bar	Air:7Bar	Air:8Bar
AS50	0°	10.5	14.3	21.9	16.2	19.0	22.8	26.6	23.0	28.3	35.2	42.8
	45°	8.2	6.7	11.9	12.0	8.2	10.8	13.6	16.5	14.3	20.0	24.7
	90°	16.2	7.6	17.1	24.2	6.2	11.4	16.2	33.3	14.0	23.8	33.3
AS65	0°	29.5	35.2	53.2	43.7	41.3	49.4	58.0	56.6	64.9	83.6	95.0
	45°	15.6	17.1	28.5	24.9	17.6	23.3	28.5	34.4	32.3	44.7	56.1
	90°	29.2	28.5	47.0	47.2	20.0	30.6	41.2	65.2	39.9	60.8	84.6
AS80	0°	47.5	71.3	104.5	76.0	76.0	95.0	114.0	114.0	123.5	156.8	190.0
	45°	33.3	28.5	52.3	42.8	33.3	42.8	57.0	61.8	61.8	80.8	99.8
	90°	61.8	47.5	95.0	85.5	42.8	61.8	85.5	118.8	85.5	128.3	171.0
AS100	0°	95.0	109.3	161.5	114.0	133.0	166.3	199.5	152.0	237.5	299.3	356.3
	45°	61.8	47.5	90.3	76.0	57.0	76.0	95.0	99.8	118.8	161.5	204.3
	90°	109.3	61.8	133.0	152.0	61.8	99.8	133.0	209.0	152.0	228.0	304.0
AS125	0°	109.3	332.5	465.5	285.0	318.3	384.8	451.3	408.5	470.3	589.0	712.5
	45°	57.0	180.5	261.3	166.3	161.5	204.3	247.0	237.5	247.0	327.8	408.5
	90°	118.8	313.5	489.3	318.3	237.5	318.3	408.5	446.5	384.8	560.5	712.5
AS140	0°	133.0	475.0	674.5	384.8	460.8	555.8	655.5	574.8	693.5	883.5	1,073.5
	45°	85.5	228.0	342.0	228.0	199.5	247.0	313.5	332.5	318.3	427.5	532.0
	90°	152.0	251.8	532.0	446.5	275.5	375.3	475.0	617.5	465.5	674.5	883.5
AS160	0°	313.5	627.0	921.5	503.5	750.5	902.5	1,045.0	888.3	1,059.3	1,339.5	1,615.0
	45°	194.8	299.3	475.0	289.8	380.0	465.5	551.0	498.8	508.3	679.3	850.3
	90°	384.8	460.8	826.5	536.8	608.0	769.5	950.0	940.5	731.5	1,121.0	1,520.0
AS185	0°	456.0	912.0	1,282.5	1,035.5	921.5	1,111.5	1,292.0	1,548.5	1,292.0	1,634.0	1,976.0
	45°	266.0	513.0	779.0	579.5	465.5	598.5	741.0	874.0	703.0	969.0	1,235.0
	90°	541.5	798.0	1,301.5	1,140.0	608.0	855.0	1,092.5	1,681.5	931.0	1,415.5	1,928.5
AS210	0°	418.0	1,577.0	2,156.5	1,206.5	1,491.5	1,833.5	2,109.0	1,681.5	2,375.0	2,945.0	3,515.0
	45°	247.0	779.0	1,149.5	674.5	717.3	921.5	1,097.3	1,035.5	1,092.5	1,463.0	1,833.5
	90°	475.0	1,197.0	1,824.0	1,239.8	978.5	1,349.0	1,719.5	1,947.5	1,472.5	2,099.5	2,707.5
AS250	0°	731.5	2,631.5	3,686.0	2,213.5	2,555.5	3,097.0	3,610.0	3,277.5	3,942.5	4,864.0	5,776.0
	45°	418.0	1,425.0	2,090.0	1,254.0	1,282.5	1,605.5	1,947.5	1,738.5	2,071.0	2,726.5	3,363.0
	90°	874.0	2,299.0	3,515.0	2,432.0	1,767.0	2,318.0	2,945.0	3,315.5	2,888.0	4,028.0	5,168.0
AS300	0°	-	-	-	6,421.0	3,637.9	4,308.0	4,547.3	8,566.0	5,740.0	6,361.8	7,270.7
	45°	-	-	-	2,283.0	1,834.1	2,172.0	2,292.7	3,046.0	2,894.0	3,207.5	3,665.7
	90°	-	-	-	3,266.0	3,712.2	4,396.0	4,640.2	4,359.0	5,857.0	6,491.5	7,418.9

*You may select spring types from strong/middle/weak; if unspecified in P/O, the standard type (as shown in the blue box) is provided.